

LAND TOWER KIT for FD200W

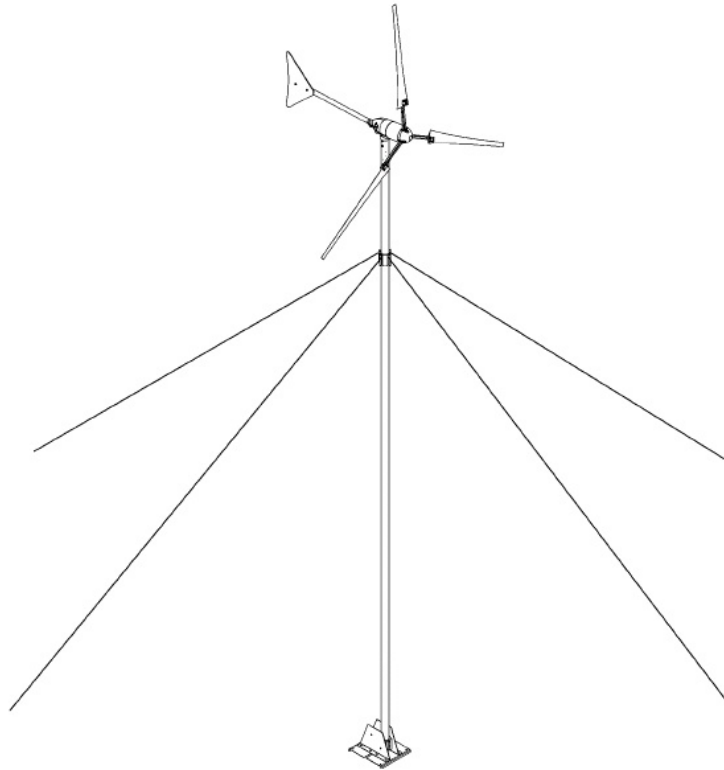

4.50 m LAND TOWER KIT

This kit is designed to be very easy to assemble and erect, however it is important that you read this manual thoroughly before beginning assembly. If you have any questions on proper installation, call your dealer for more information.

Safe Installation

Safety is the most important consideration to take into account when installing a tower and wind turbine. It is very important to remember that any wind turbine has high speed spinning parts and can be very dangerous if not installed properly! Be sure that tubing or pipe used for the tower is of adequate strength, all bolted connections are tightened to the proper torque and the guy wire anchors are suitable for your conditions, terrain and size of tower. All of these elements are explained in further detail later in this manual. **Important! Choose a very calm day to do your installation. A gust of wind at the wrong moment could cause VERY SERIOUS PROBLEMS!**
PLEASE...READ THIS ENTIRE MANUAL BEFORE DOING ANYTHING!

4.50 m Tower Kit Parts List

Your Tower Kit includes:

Quantity

Earth Anchors	4
Tubing or Pipe for Tower(1.50m/pc)	3
Guy Wires	4
Electrical Wire	1
Ground Rod	4
Tower base	1
Cable Thimbles	4
Cable Clamps	12
Pivot Bolt and Nut	1
Tower Insert	1

Please inspect the contents to see that all parts are present and to familiarize yourself with the pieces before beginning assembly.

Tools Needed:

Sawhorse	Ladder of 10 foot(3m)2x6 or 2x8
Lifting Rope	Torque Wrench

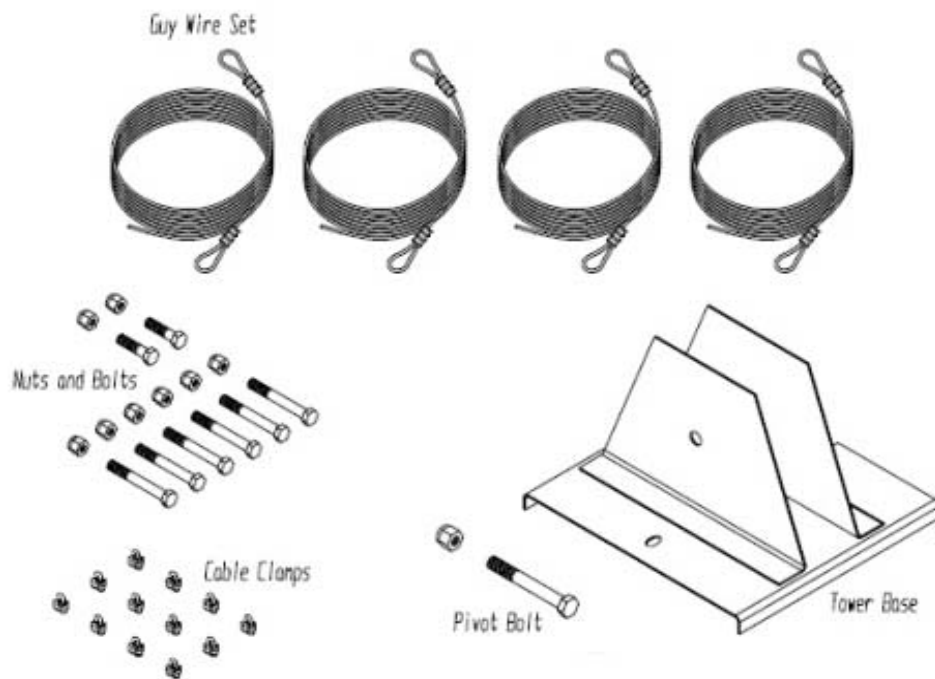

Step 1: Site Selection

Site selection is the most important in affecting the performance of your wind turbine.

The energy in the wind is the kinetic energy of the moving air mass. What a wind turbine does is convert some of that kinetic energy into rotational energy that can then be converted to electricity.

The formula for the amount of power in the wind is a cube function of the wind speed. This means basically that an increase in wind speed of 10% (say from 9 mph to 10 mph) will result in approximately a 37% increase in the power available from the wind and a similar increase in turbine performance. In almost all locations the wind speed increases as you get higher off the ground. This is why a tall tower is very important at most wind sites. As a rule, the turbine should be mounted as high in air and as far away from obstructions as is possible.

To find the best location to erect your tower and wind turbine, study the available area and take note of how the prevailing (most common) winds blow through it. If there are trees, buildings, hills or other obstructions take note of how high they are and where they are in relation to the prevailing wind direction. The best site for your tower and turbine will be upwind and above any obstructions that may exist. If there are houses or trees in the surrounding area a good rule of thumb is to mount the turbine at least 15 feet above any obstructions within 500 feet (150m) of it.

The next consideration in siting your tower and turbine is the distance from the turbine to your batteries. The shortest distance will require the least amount of wire, allow use of the most economical (smallest) wire and reduce the amount of power lost through the wiring. If a long distance is required between your tower and the batteries it will be necessary to use heavy gauge wire to reduce the resistance of the wire. The power consumed by the wires can be calculated using the formula:

$$\text{Power} = \text{Current} \times \text{Current} \times \text{Resistance}$$

Since the resistance of the wire is directly proportional to its length, making the run shorter will dramatically reduce the amount of power "lost" in the wires. See your turbine owner's manual for wire sizing charts.

Please refer to the section on "Tower, Base and Anchor Layout". The amount of space available to assemble and raise the tower may also affect where your tower can be placed.

Step 2: Tower, Base and Anchor Layout

This tower kit should only be assembled on a calm day (no wind). The tower base and anchors should be laid out as described in the drawing below.

The tower will be assembled laying on the ground and then tilted up into position.

If the tower is being erected on a slope it will be much easier to raise the tower if it is assembled to the uphill side of the base as it will already be part way up as it is erected. In this case the two "side" anchors should be at the same height or elevation on the hill as the tower base. The two remaining anchors should be directly uphill and downhill from the tower base.

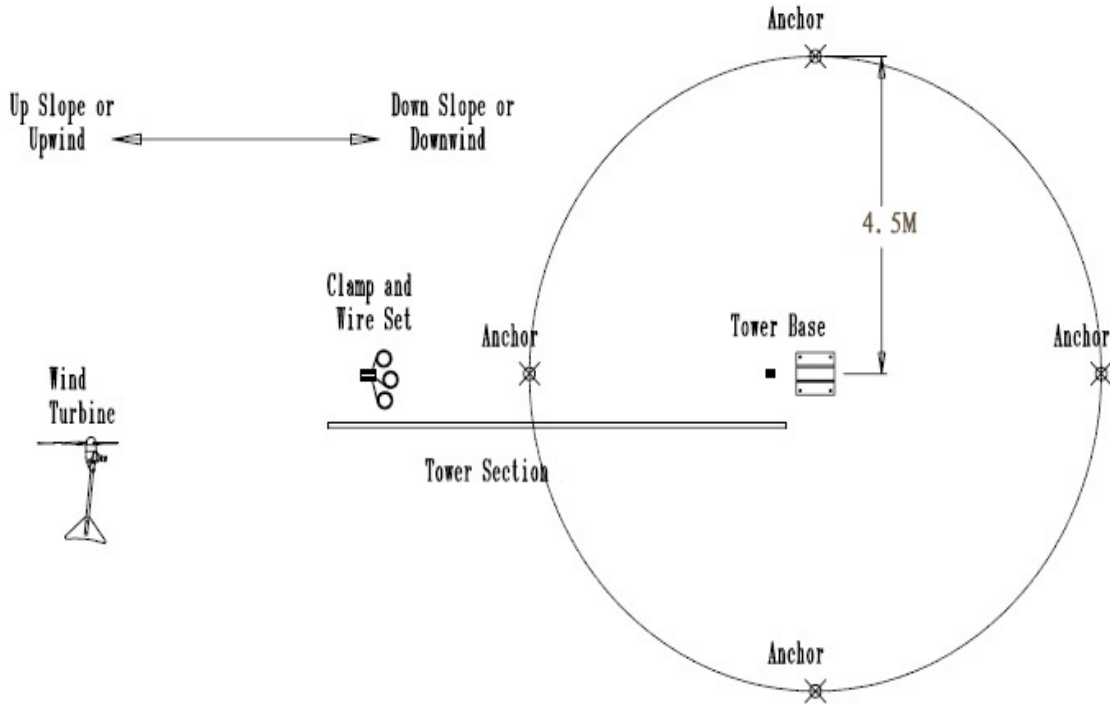

Be sure that the anchor points and base position are in a line when sighted from anchor to anchor. This will insure that the forces on the guy wires are balanced properly, make final guy wire adjustments simpler and will help a great deal during the actual raising of the tower. The side anchors and tower base should also be at the same elevation. If either of these requirements are not met, the guy wires will either tighten excessively or go slack as the tower is raised. **If the guy wires tighten excessively the tower may buckle and collapse, causing possible injury or even death and at the very least, damage to both the tower and the turbine. Carefully read this section on raising the tower for further instructions on making the proper adjustments in these situations.**

Step 3: Tower Base Assembly

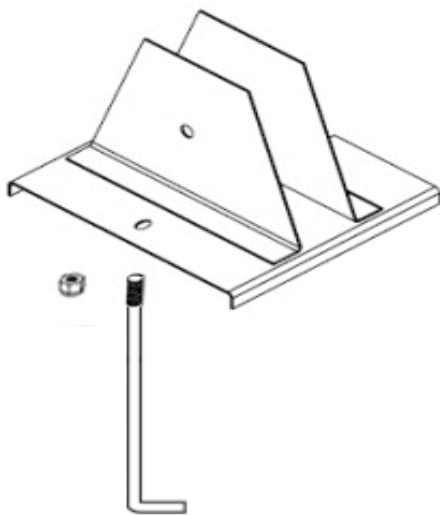

Secure base with stakes or steel re-bar driven into the ground or bolts in concrete.

Step 4: Guy Wire Anchor Installation

There are four types of anchors that are most commonly used with our towers; screw in “Auger” type anchors, hammer driven “duckbill” anchors, cast concrete anchors and expansion bolts (for use only in solid rock). **What anchor should be used depends on the soil type that the anchors will be placed in.** See the following table for our suggestions:

<u>Soil Type</u>	<u>Recommended Anchor</u>	<u>Alternatives</u>
Sand	Concrete	None
Loose Gravel	Concrete	None
Loam	Auger	Duckbill, Concrete
Clay	Duckbill	Auger, Concrete
Rocky Soil	Duckbill	Concrete
Gravelly Soil	Auger or Duckbill	Concrete
Solid(Soft) Rock	Large, Long Expansion Bolt	Large Eye Bolt + Cement
Solid(Soft) Rock	Smaller Expansion Bolt	None

The loads on a single anchor can exceed 1,500 lb. in a 100-mph gale. Make sure that the anchors chosen can withstand at least this much force or the tower will have to lower during storms. Augers and Duckbill anchors are frequently available at mobile home supply stores. Augers are also available from the dealer where your turbine was purchased. Expansion bolts for anchoring in solid rock can be purchased at most hardware stores.

Augers: If the soil conditions make their use feasible, augers are the simplest anchors to install. Augers screw into the ground using either a piece of wood, pipe or rod as a “cheater bar”. If a mistake is made or if the tower must be removed an auger can be “unscrewed” out of the ground and reused. They depend on the soil holding together for their strength and are not suitable for sand or loose gravel. If the soil is rocky or clay-like you may have difficulty screwing them in.

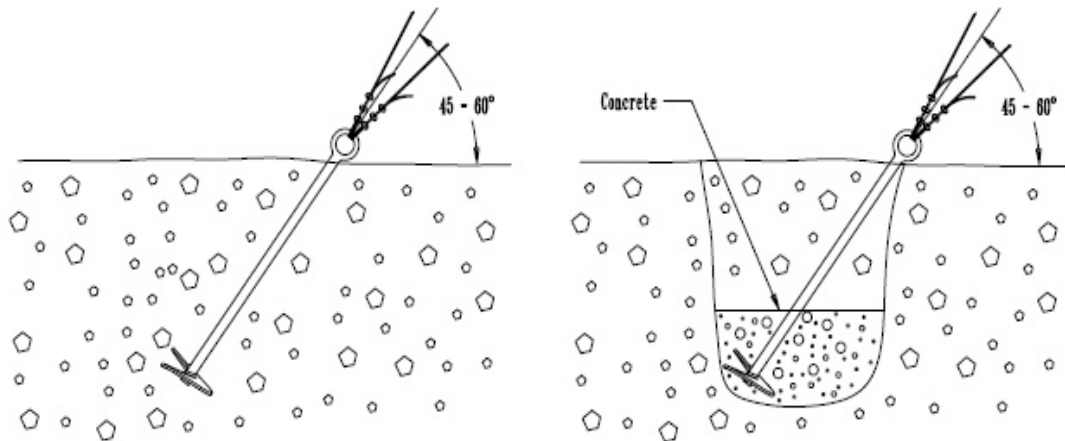

An auger is usually installed by screwing it straight into the ground a few turns to get it started and then tilting it to the desired angle once it is into the ground a few inches. A substantial downward pressure is usually necessary to get an auger started. Screw the augers in as far as possible for the

greatest strength.

Augers depend on the ability of the soil to hold together for their strength. If augers cannot be screwed in, simply digging a hole and burying them will not work. We recommend buying augers, and if they cannot be screwed in properly, a hole can be dug and the auger can then be cast in the concrete. This will provide a good loop for guy wire attachment and make an excellent anchor in the concrete.

Duckbill Anchors: Duckbill anchors consist of an anchor attached to a cable with a loop on the end. They are driven into the ground using an anchor driver, which is a steel rod with either an enlarged striking surface (for a large hammer) or an attachment for a jackhammer or impact driver. The anchor driver fits into the anchor and holds it straight while it is being driven into the ground. Once the anchor is sufficiently deep in the ground, the driver is withdrawn and the anchor cable is pulled a short distance to “set” the anchor. As the anchor is being set it will rotate perpendicular to the hole made as it was driven in, making it very difficult to move any further.

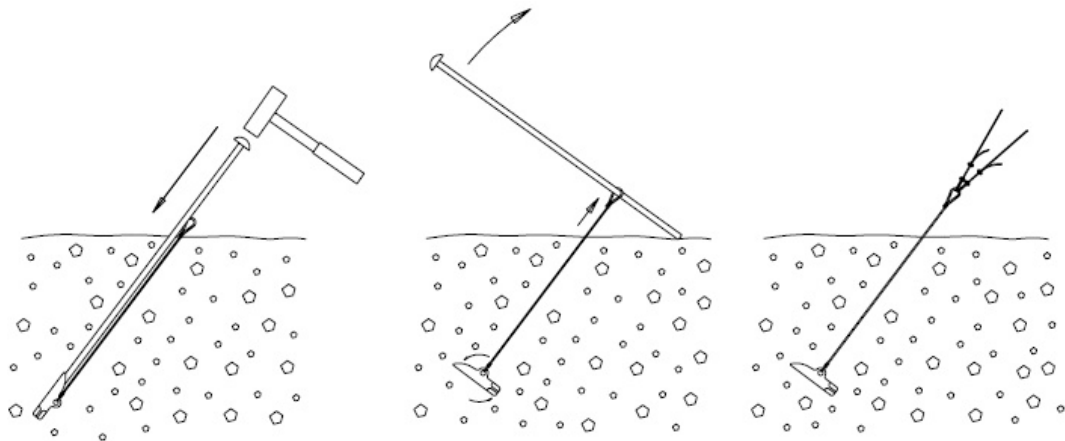

Please note that once a duckbill anchor is set in place it cannot be removed without digging it out

Buried Concrete: A buried concrete anchor may be the only solution if the ground is loose gravel or sand or if it is too rocky for an auger or duckbill to be driven in. Buried concrete anchors will work in any situation other than solid rock. A hole must be dug in the ground at the desired anchor point. One good tactic is to purchase either augers or duckbills and if they cannot be used as intended, then dig holes and cast them in concrete. Otherwise some other means of attachment must be created for the guy wires, such as a loop of steel reinforcing bar (re-bar) or chain.

Step5: Assembly of Tower and Turbine

The tower is assembled lying on the ground and then lifted onto a sawhorse or large box so that the turbine can be mounted to it.

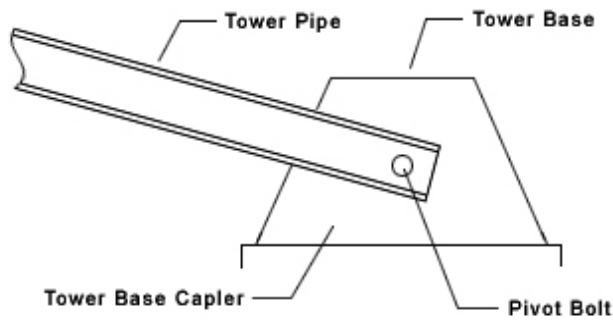

- 1) Lay the tower pipe on the ground and locate it into the tower base.
- 2) Install the pivot bolt and nut through the base and pipe. Tighten so they are just barely snug, not tight, against the tower base.
- 3) Raise the turbine end of the tower pipe and set it on a saw horse or other supporting object. The end of the tower should be at least 1 m off the ground.
- 4) Run the turbine wires through the tower pipe and lead it out from the bottom of the tower pipe.
- 5) Connect the flange of the turbine together with the flange of the tower by bolt and nut.
- 6) Install the guy wire set onto the tower pipe. The center of the clamping piece should be located 1.52 m from tower top.

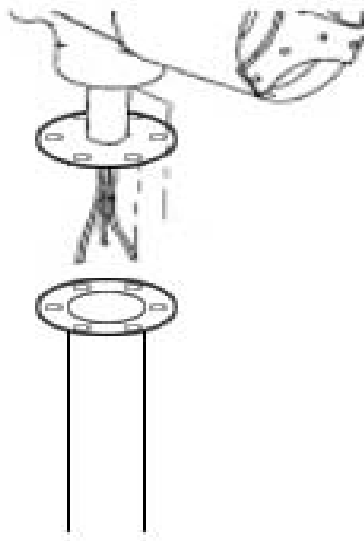

Step 6: Attaching Guy Wires to Anchors

With the assembled tower laying on the ground the guy wires at the sides and rear of the tower should now be attached. Leave about 7.5 cm of slack in the wires to allow for any misalignment or unnoted elevation differences (the wires will be adjusted more precisely later). The side wires can be pulled to their anchors and attached using the wire rope turnbuckle/thimbles provided with your tower kit.

The rear guy wire length can be estimated by pulling it to a side anchor and placing a piece of tape

On the wire at the distance of the side anchor. The rear wire will then be attached to its respective anchor at the point marked by the tape. This should make their length approximately correct when the tower is up (again these will be readjusted, so don't worry about a couple of inches (5cm) one way or the other). Make sure that none of the guy wires are crossed and that the sidewires are straight with no rear wires on top of them. Run the tail of each guy wire through the second clamp twice, forming a safety loop.

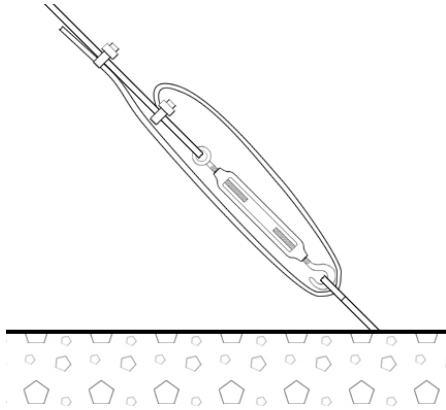

Step 7: Raising the Tower

Before attempting to raise the tower make sure that all side and rear guy wires are attached and that all cable clamps are tight. Also be sure that the two bolts on the guy wire hanger are tight.

- 1) Once the rear and side guy wires are attached, attach the "lifting" guy wire to a pulling rope, chain or cable attached to a vehicle, winch or work animal. (pulling rope should test to at least 1,000 lb or 450 kg for safety). At least fifty 16 m of rope will be needed to erect this tower.
- 2) Run the rope and lifting wire over the end of the 2x6 or 2x8 of ladder as shown on following page to form a crude, but effective gin pole (see drawings on following page).
- 3) At this time all persons nearby should move to a safe distance (at least 10 m from the tower while it is being raised).
- 4) Move the vehicle forward slowly to take the slack out of the lifting wire. Slowly proceed until the tower lifts off of the sawhorse. Pull and stop every 15 degrees (tower's angle to horizontal) or so and observe the side guy wires. If they start getting too tight, stop the vehicle and slowly reverse to set the tower back down. This is usually caused by the ground at the base being slightly higher than the ground at the side guy wire anchors, or if the anchors and the base are not in a straight line. If this occurs immediately lower the tower back to the ground and adjust the side guy wires a few inches looser.

Failure to adjust the guy wires properly before raising the tower may cause the tower to buckle and collapse, seriously damaging the turbine and tower and possibly causing serious personal injury or death!

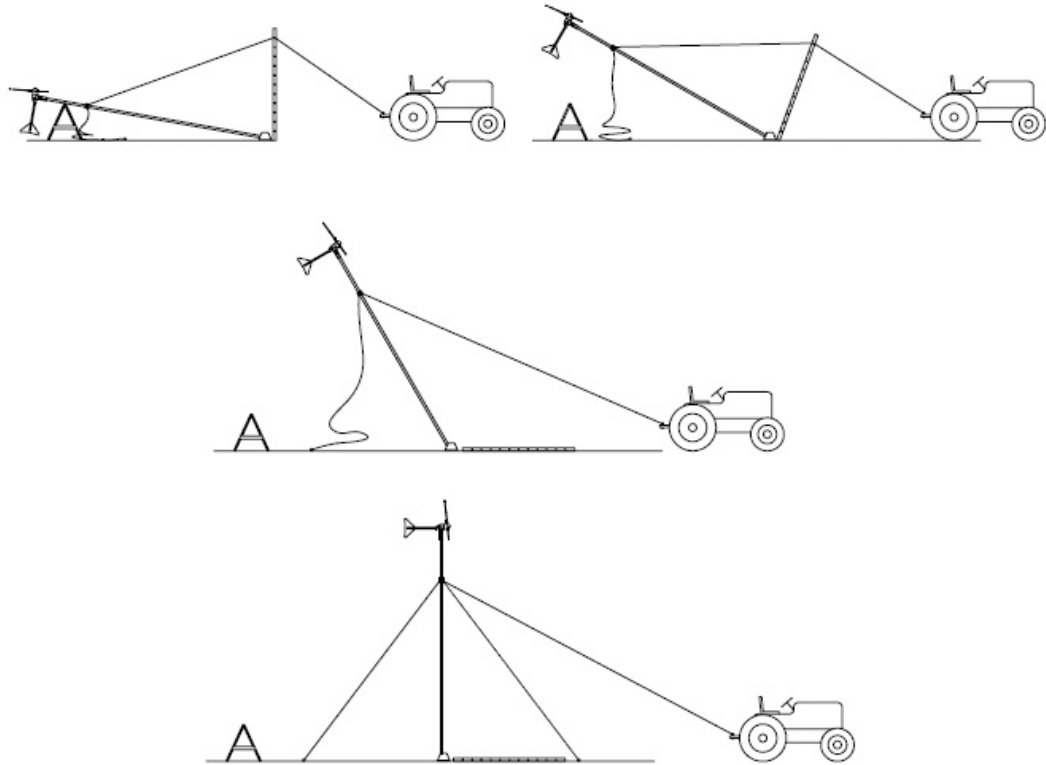

- 5) The board or ladder will fall out of the way after it has done its job. This is ok, just remember to put it back in position when lowering the tower.
- 6) continue forward until tower is vertical, stop vehicle, set brake, leave in gear and shut off engine. Be sure not to pull too far or the tower may buckle and collapse.
- 7) Remove lifting wire from rope and vehicle and attach to lifting side anchor as described in step 6 (attaching cables to anchors). Maintain some tension on the lifting wire while the cable is being attached to prevent tower from falling back down.
- 8) At this point the tower should be checked for guy wires that are slightly too tight or too loose. Guy wires that are too tight will cause the tower to bow. If they are too loose the tower will usually Sway back and forth a bit. The proper tension is where there is no tension and no slack. This is Easily achieved by hand without turnbuckles.

Step 8: Final Adjustment of Guy Wires

Check to see if any of the guy wires are too tight and are causing the tower to bow. A tower with slightly loose wires is safer than a tower with wires that are too tight. If there are, determine which wires) are too tight(the wires act in pairs) and release the tension on one of the wire. To relieve tension on a wire, loosen the turnbuckle.

The tension on the wires should be light and can be set by pulling the wire by hand. It is easy to over tighten the guy wires, even by hand. Once adjusted, be sure to re-tighten the cable clamp nuts.

Now walk a short distance from the tower and look to evaluate whether the tower is straight or leaning to one side(a carpenter' s level held against the tower can be helpful for this). You will need to

loosen one wire and tighten the wire opposite to it. Check the tower straightness and repeat the process until the tower is straight.

When you are finished, make sure that all the cable clamps are tight. If the tower is to be lowered, only unclamp the cable on the lifting wire side so that when the tower is re-erected only that cable will need to be readjusted.

Maintenance

Periodically check to see that the guy wire tension is set properly. Typically there is no other maintenance required for this tower. Keep your setup kit in a safe place in case the tower needs to be moved or the turbine requires service.

Step 9: Lowering the Tower

If it is necessary to lower your tower for any reason, follow these steps:

- 1) Disconnect your turbine wires at the controller.
- 2) “Short” the wires together to stop the turbine from spinning
- 3) Disconnect the guy wire on the lifting wire side only. Attach it to the wick or vehicle.
- 4) Position a sawhorse where the tower is expected to come to the ground to protect the turbine blades from damage.
- 5) Tip the tower by hand until the lifting wire is taut and supporting the tower.
- 6) Position a ladder under the lifting wire to act as a gin pole while lowering.
- 7) Slowly lower the tower until it is resting on the saw horse.