

# Owners Manual

## FD500W/FD1KW Wind Generator

### **BEFORE YOU BEGIN:**

Read this entire manual. Following the instructions and recommendation in this manual will help assure safe and enjoyable use of your new renewable energy system.

**SAFETY INFORMATION:** these systems present mechanical, electrical and chemical(battery) hazards that can be life threatening. The tower or support structure could fall and cause injury or death and property destruction. A component of the wind generator could come loose causing injury or death. High voltage from the wind generator or the inverter can cause injury or electrocution. A burn injury can result from an electrical short. A severe chemical burn including blinding can occur from a battery explosion or contact with the sulphuric acid in a lead-acid battery.

These conditions are addressed in the following safety messages:

**STOP! DANGER!** It is your responsibility to obtain all required permits and engineering certifications for your tower and tower location. Soil and wind conditions vary and tower foundations must be designed for your specific location. Tower must not be able to fall on occupied buildings, neighbour's property or power lines. Tower climbing is dangerous and should be attempted only by experienced personnel using proper safety equipment. Locate your mounting mast(tower) well away from occupied buildings and power lines: a minimum of 100m is recommended.

**STOP! DANGER!** If the generator appears or sounds loose in the tower or is making an unusual sound, the condition must be corrected immediately. A loose generator or component will soon damage itself further and may fall from the tower or lose parts that could be lethal. Never stand in line with an operating propeller.

**STOP! DANGER!** Provide climbing protection against all unauthorized persons or children. Never allow an untrained person or someone without the proper safety equipment to climb the tower. Always stop the propeller before climbing the tower. Both falling from the tower and contact with the operating propeller can be lethal.

**STOP! DANGER!** High voltage systems(system with inverter) represent a dangerous shock hazard and could be lethal. All high voltage systems should be wired and maintained by a qualified and licensed electrician.

**STOP! DANGER!** Batteries may emit explosive and irritating gas while charging. Never turn on a light switch or make any other electrical connection or light a match or make any type of spark near a recently-charged battery. Use protective gloves and eyeglasses when working around a battery. Turn off all loads, wear safety glasses, and look away when making a final battery connection.

**STOP! DANGER!** Never put objects on top or near the charge controller, inverter, aurora wind interface, when applicable. These devices must dissipate heat as part of normal operation. FIRE AND FAILURE can result if airflow is blocked.

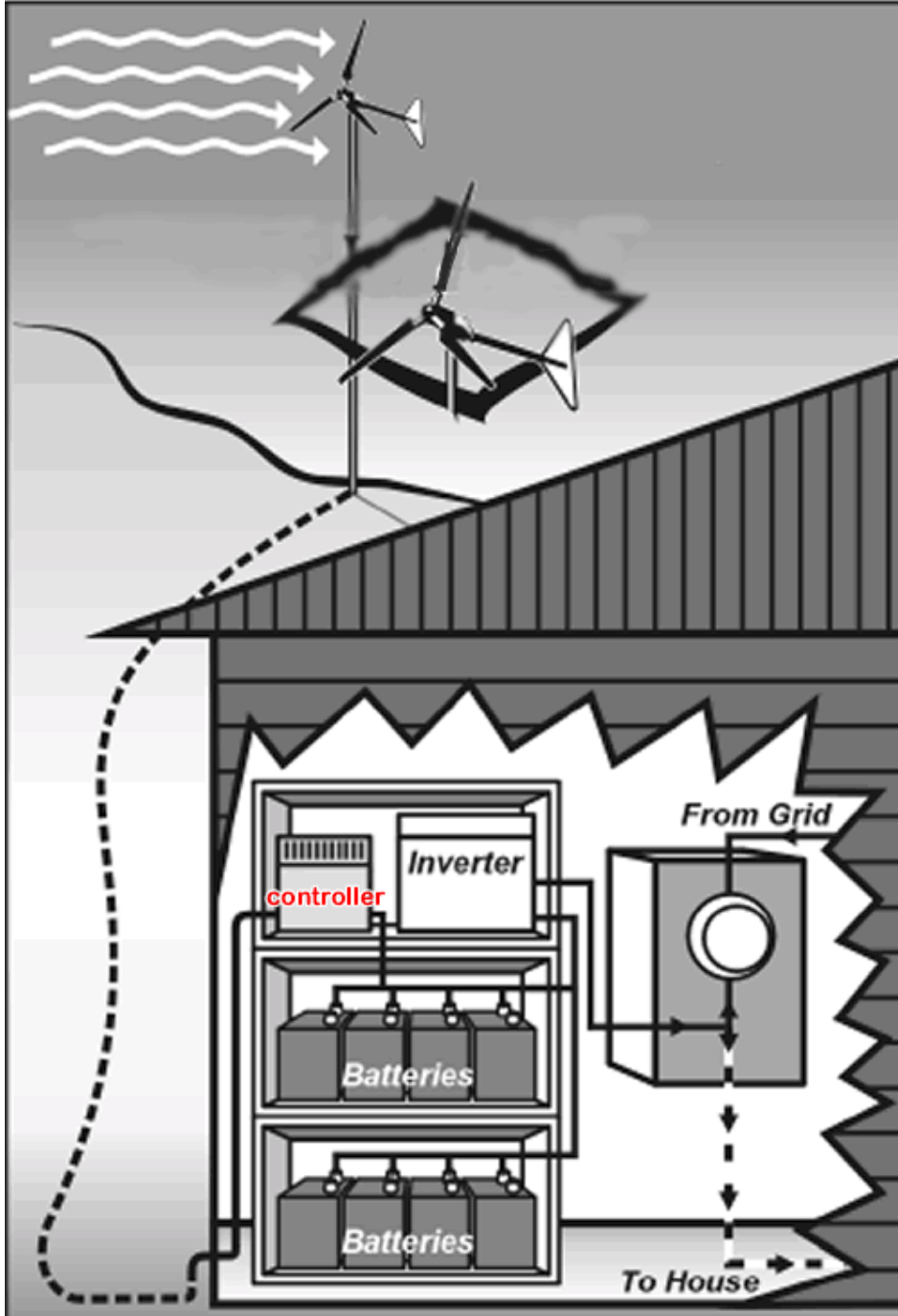

## 1. Overview

The FD500W/FD1KW wind turbine generator system is a state of –the-art small generator designed to charge batteries and supply electrical loads in a 36V or 48V power system. When used in conjunction with a suitable sine wave DC-AC inverter and a battery bank, it can also be connected to the power grid.

The FD500W/FD1KW wind turbine generator features superior low-wind-speed performance, very high system efficiency .

The FD500W/FD1KW is offered with the optional guyed tubular tilt tower, which comes in heights of 6m. For installation procedures on this tower please refer to “6m land tower kit”.

## Specifications

Model	FD500W	FD1KW
Rated Power	500W	1KW
Max Power	700W	1.5KW
DC output	24V or 36V	36V or 48V
Start Wind Speed	3m/s	
Rated Wind Speed	8m/s	
MAX WIND SPEED	20m/s	
Cut-Out Wind Speed	None	
Blade Pitch Control	None, Fixed Pitch	
Over speed Protection	Auto Furl	
Gearbox	None, Direct Drive	
Temperature Range	-40 to +60 Deg. C	
Rotor Diameter	2.70 m	3.10 m
Rotor speed	400 rpm	
blade	3	
Blade material	Reinforced fibreglass	
Height of tower	6.0 m	
Generator	3 phase permanent magnet alternator	
Inverter power output	AC 110/220V, 50HZ/60HZ	
Weight(kg)	90	100

### ***When unpacked the kit should contain:***

- 3 tower sections
- 1 tail boom
- 3 aerofoil blades
- 1 large alternator connected to a length of cable
- 1 hub
- 1 tail vane
- 1 baseplate for tower
- 2 steel pegs for baseplate
- 3 angled pegs for guylines
- 6 U-clamps for guylines
- 3 tensioners for guylines
- 3 lengths of wire for guylines
- 1 nose cone

1 charge controller  
various nuts and bolts for assembling the system.

Optional: 1 DC-AC inverter

## 2. System Description

The major components of the FD500W/FD1KW wind generator are shown as below.

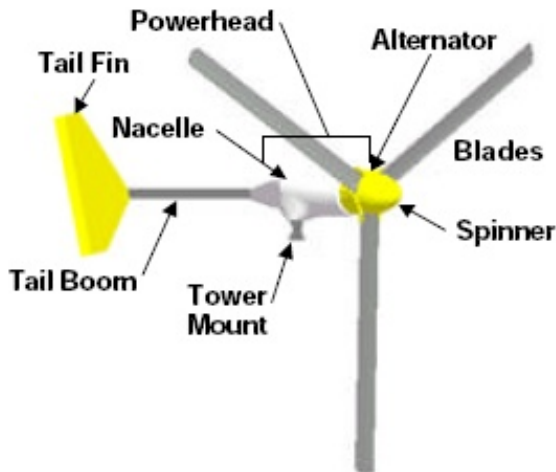

*Components of a wind energy*

*system.*

### **Blades/Rotor System**

The rotor system consists of three fibreglass blades. Acting like aircraft wings, the blades convert the energy of the wind into rotational forces that can drive a generator. The rotor has three blades because three blades will run much smoother than rotors with two blades.

#### **A. Alternator**

The FD500W/FD1KW wind generator is a horizontal axis wind generator. The alternator utilizes permanent magnets and has an inverted configuration in that the outside housing(magnet can) rotates, while the internal windings and central shaft are stationary.

The output from the alternator is three-phase alternating current(ac), but it is rectified to direct current by the charge controller which is a part of the system. Since it uses permanent magnets, the alternator is generating voltage whenever the rotor is turning.

#### **B. Nacelle**

The nacelle is the aluminium housing around the main body of the machine. It contains the main structural backbone of the turbine(called the mainframe), the slip-ring assembly, the yaw bearings, and the tower mount. The yaw bearings allow the wind turbine to freely pivot around the top of the tower so that the rotor will face into the wind.

The slip-ring assembly is the electrical connection between the moving(as it orients with the wind direction) wind turbine and the fixed tower wiring. The slip-rings and yaw bearing are located just above the tower mount. The tower mount attaches the FD series wind turbine to the top of the tower.

### **C. Tail Assembly and AutoFurl Operation**

The tail assembly, composed of a tail boom and the tail fin, keeps the rotor aligned into the wind at wind speeds below approximately 12 m/s. At about 12 m/s the AutoFurl action turns the rotor away from the wind to limit its speed. The tail appears to fold, but in reality the tail stays stationary, as the rotor turns sideways to the wind. The rotor does not, however, furl completely sideways. This allows the turbine to continue to produce power in high winds. When the high winds subside the AutoFurl system automatically restores the turbine to the normal straight position.

### **D. Charge Controller**

The charge controller serves as the central connection point for the electrical components in the system and it provides 2 valuable control functions. It rectifies the AC output from the turbine into direct current(DC) and charge the battery.

The controller continually monitors the battery voltage and compares it to the regulation set point. The regulation set point is factory set to 36V or 48V. When the battery voltage rises above the set point, the built-in extra load(dump load) circuit is ramped up to control the battery voltage. It will wait for the battery voltage to drop. Normal charging will resume when the battery voltage drops slightly below the fully charge level. For 36 V turbine the controller will resume charging at 32 V.

## **System Operation**

### **A. Normal Operation**

The rotor of the FD500W/FD1KW should begin to rotate when the wind speed reaches approximately 3m/s. (for the first several weeks of operation, however, the start-up wind speed will be higher because the bearing seals have not worn in) battery charging should commence shortly after the rotor spins up to speed. Once turning, the rotor will continue to turn in lower wind speeds, down to approximately 2.5m/s. the rotor speed will increase with increasing wind speed and the system will provide a higher output. This output increase rapidly because the energy available in the wind varies as the third power(cube) of the wind speed. For example, if the wind speed doubles from 5m/s to 10m/s, the energy in the wind increases by a factor of eight( $2^3=2 \times 2 \times 2=8$ ). One result of this relationship is that there is very little energy available in light winds. For the average site, winds in the range of 5.5-12m/s will provide most of the system annual energy production.

### **B. High Winds – AutoFurl**

During periods of high wind speeds the AutoFurl system will automatically protect the wind turbine. When furlled, the power output of the turbine will be significantly reduced. In winds between 13m/s and 18m/s it is normal for the turbine to repeatedly furl, unfurl and then furl again. In winds above 18m/s the turbine should remain continuously furlled.

AutoFurl is a simple and elegant method of providing high wind speed protection. The AutoFurl system is based on aerodynamic forces on the rotor, gravity, and the carefully engineered geometry of the wind turbine. As shown in Figure, the aerodynamic forces acting on the blades cause a thrust force pushing back on the

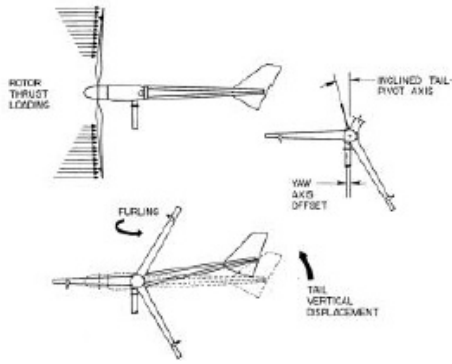

rotor. This force increases with increasing wind speeds. The thrust force acts through the centreline of the rotor, which is offset from the centreline of the tower pivot axis(yaw axis). Therefore, the thrust force on the rotor is always trying to push the rotor over to the side, away from the wind.

But the rotor is kept facing into the wind at speeds up to  $\sim 12.5\text{m/s}$  by the wind turbine tail assembly. The tail, in turn, is kept straight by its own weight because its pivot at the back of the nacelle is inclined. So the weight of the tail holds it against a rubber bumper and the tail holds the rotor into the wind.

The geometries in the systems are carefully balanced so that at  $\sim 12.5\text{m/s}$  the rotor force acting on the yaw-offset is large enough to overcome the preset force holding the tail straight. At this point the rotor will start turning away from the wind or furling. The tail stays aligned with the wind direction. The speed of furling depends on the severity of the wind gusts and whether the wind turbine stays furling depends on the wind speed.

As the wind turbine furls the geometry of the tail pivot caused the tail to lift slightly. When the high winds subside the weight of the tail assembly returns the whole turbine to the straight position. The AutoFurl system works whether the turbine is loaded or unloaded.

The AutoFurl system is completely passive, so it is very reliable and since there are no wear points, like in a mechanical brake system, it is very robust.

There is one situation in the field, however, that we have found can disrupt the operation of AutoFurl. If the wind turbine is installed on a sharp hill or next to a cliff so that the wind can come up through the rotor on an incline(e.g., from below; as opposed to horizontally) we know that this will affect furling and can produce higher peak outputs. We strongly recommend avoiding this situation.

The wind generator is designed to survive in wind speeds of up to  $30\text{m/s}$ .

### **3. Wind Generator Installation**

### **Electrical Tests**

Complete these tests before mounting blades to rotor, and before installing turbine to top of tower. These tests confirm that the wind generator is functional and ready to install on the tower.

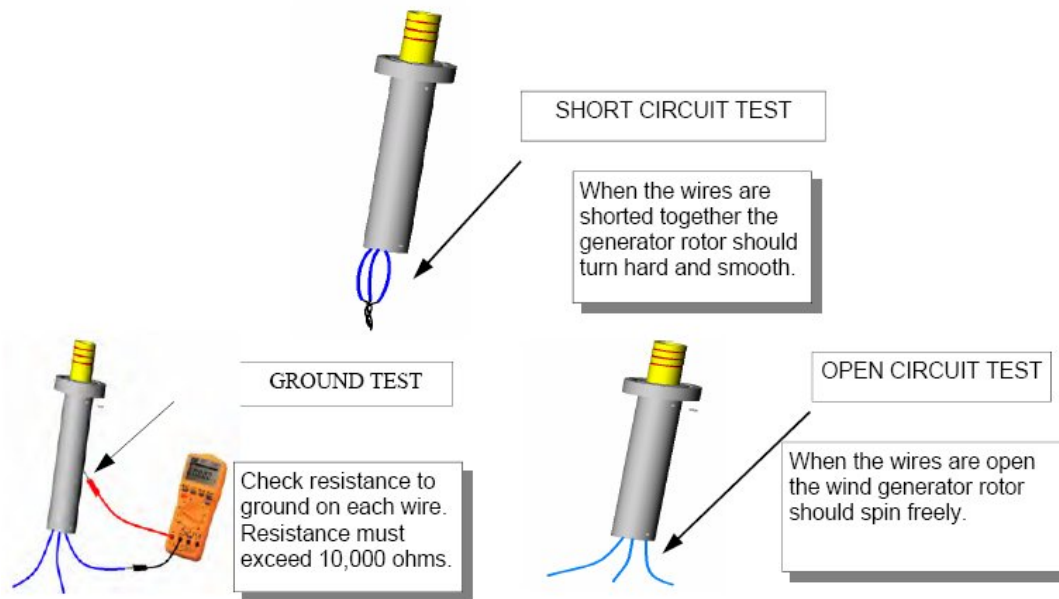

*Diagram of a grid-tied wind electric system.*

## **4.. Charge Controller Installation**

The general electrical configuration is shown in Figure as below. In most cases the loads will be AC(alternating current) and they will be supplied through a DC-to-AC inverter.

The charge controller must be installed indoors and should be located relatively close the battery bank. Do not install the charge controller outdoors; it is not waterproof.

### **Step 1.**

Connect battery leads. First connect the battery negative(-) wire to the terminal marked (-). Touch the positive terminal (red colour) with battery positive wire and withdraw quickly. If a big spark takes place, the connections are reversed. Double check everything to find the cause. Connect the battery positive wire to the terminal of red colour after checking. **WARNING! The user must connect batteries to the wind generator system. Without batteries, the wind turbine will not turn and may be damaged after some time!**

### **Step 2.**

Connect the three wind turbine leads to the three terminals on the controller panel. The three wires are interchangeable and are not labelled. Any leads can go to any terminal. The turbine leads should still be shorted from the turbine installation. In order to make the connections to the controller a small wire can connected to allow the turbine wires to remain shorted until the wires are fully connected to the controller.

Once all turbine leads are connected, remove the shorting wire. If there is sufficient wind then the turbine will begin turning and the turbine LED will begin blinking, indicating that the turbine is charging the battery.

### Step 3.

Connect inverter. If the system includes a DC to AC inverter, connect the inverter input leads to the battery terminals, not to the charge controller. The controller circuit board is not designed to handle the high currents that are possible with inverters.

. Ensure that you have the correct battery size for your system (500W and 1KW units normally utilise 36V or 48v batteries respectively. Ensure that the batteries used are identical types and of identical age. Mixing different types/sizes/ages of battery will cause all the batteries in the bank to fail prematurely. If you need to replace batteries, you should replace all at once.

The charge controller should be connected to the battery via it's red and black outputs (red=positive, black=negative). Ensure that you have the correct battery size for your system (500W units normally utilise 36v batteries while 1KW units utilise 48v batteries). You can make up a 36v battery out of 3 x 12v batteries wired in series and a 48V battery out of 4 x 12v batteries. Ensure that the batteries used are identical types and of identical age. Mixing different types/sizes/ages of battery will cause all the batteries in the bank to fail prematurely. If you need to replace batteries, you should replace all at once.

## **Batteries**

You can use any type or size of battery. However, car batteries are not designed to cope with deep charge/discharge cycles, and so they will not have a long lifespan. Truck batteries are a little better, and leisure batteries are better still. Dedicated 'deep cycle' batteries are the best option, as they have larger plates, larger gaps between plates, and more clearance between the plates and the bottom of the battery casing, to allow greater debris build-up before problems arise. If you are unsure about the batteries, please contact your supplier, who can advise you further.

# **5. Inverter(optional)**

## **I. General Introduction**

This device transforms the DC power energy into a 220V 50Hz AC power source. The device produces a modified-sine wave, which is suitable for powering many, but not all types of equipment.

## **II. Performance**

The inveter incorporates specially designed American micro-processors for control and German IXYS MOSFET transistors together with Japanese intelligent power IGBT module (IPM) as the main circuit. This power source has the characteristics of

good transient response, high contra-variant efficiency, stable output voltage and so on, and has the best EMI index at the same time. This power source is provided with a series of protection measures such as DC input over-voltage and under-voltage protection, DC input reversal polarity connection protection, AC output over-voltage, over-power and short-circuit protection as well as the machine's internal over-temperature protection and so on, enabling high performance under all conditions

### **III. Operation Scope**

This inverter has been designed and manufactured in line with the characteristics of renewable energy generating systems, and is mainly used for the wind and solar power systems.

### **IV. Caution**

1. There is a 220V AC high voltage electricity in the socket of the inverter, please put it in a place where children cannot reach.
2. Please don't put the inverter in a damp place; it should be located in an environment with good ventilation and protected from the elements.
3. When the fan is in operation, please ensure that you keep fingers etc away from its blades

### **V. Technical Indexes**

**Please see the manual of '500W or 1KW'.**

### **VI. Protective Functions**

1. DC under-voltage protection: When the DC voltage is lower than 88% of the rated voltage, the bias indicator light turns on, the output is blocked; and the output will be restored automatically after the DC voltage has risen.
2. DC over-voltage protection: When the DC voltage is higher than the rated voltage by 30%, the bias indicator light will flash, the output is blocked; and the output will be restored automatically after the DC voltage has lowered.
3. Output short-circuit protection: If by any chance the AC output is short-circuited, the over-load indicator light turns on and the output is blocked, and the output can be restored only by turning off the machine and then re-starting it.
4. Output over-load protection: When the output load reaches 120% of the load of rated power for 10 minutes or reaches 150% of the load of rated power for 4 seconds, the over-load protection activates.
5. DC input reversal connection protection: When the "+" and "-" of the inverter input are connected in a reverse way, there will be no output. However, the unit will be protected against damage, and will function correctly once the wiring fault has been rectified.

### **VII. Installation and Operation**

**DO NOT CONNECT THE WIND TURBINE TO THE INVERTER WITHOUT CONNECTING BATTERIES.** The inverter will not work, and will suffer irreparable damage.

**DO NOT DISCONNECT BATTERIES WHILST INVERTER IS RUNNING** – permanent damage will occur.

1. Place the switch in position "OFF".

2. Use a copper wire with a diameter greater than 6 mm to connect pole “+” of the battery with pole “+” of the inverter and pole “-” of the battery with pole “-” of the inverter.
3. Connect the load with the terminals of “AC 220V” of the inverter.
4. Place the switch in position “ON”.

## **6. Maintenance**

A wind turbine requires periodic maintenance such as oiling and greasing, and regular safety inspections. Check bolts and electrical connections annually; tighten if necessary. Once a year check wind turbines and towers for corrosion or cracks and check the guy wires supporting the tower for proper tension on a monthly basis.

After 10 years, blades and bearings may need to be completely replaced. With proper installation and maintenance, your turbine can last 20-30 years or longer. Proper maintenance will also minimize the amount of mechanical noise produced by your wind turbine.

### **LIMITED WARRANTY**

We provide free replacement cover for all defects in parts and workmanship for two years from the date of purchase. Our obligation in this respect is limited to replacing parts which have been promptly reported to the seller as having been in his opinion defective and are so found by us upon inspection.

Defective parts must be returned by prepaid post to us, or to an authorised agent.

This warranty is void in the event of improper installation, owner neglect or natural disasters and does not extend to inverters.

No responsibility is assumed for incidental or consequential damage, damage caused by the use of any unauthorised components.